

## STANDARD FEATURES

- Cooking capacity for up to six 12"x20"x2.5" deep steam table pans.
- 304 Stainless Steel interior and exterior construction.
- Steam flow directed over each pan from both left and right side of cooking chamber for more even cooking.
- Hold Mode with adjustable thermostat.
- Heavy duty refrigeration style door handle with magnetic latch.
- 60 minute timer with continuous cook and hold mode features.
- UL Listed, UL Classified to NSF/ANSI 4 and exceeds Energy Star® performance levels.
- Electric heating element not exposed to water and requires no scheduled de-liming.
- No water filtration or treatment required.
- No warranty exclusion for water quality.
- Controls include options for both batch and à la carte cooking modes.
- Bullet feet, 6 foot cord and plug set included.
- One year Parts and Labor Warranty included.

## OPTIONS

- Automatic water fill controls; fills when main power is turned ON. Low and High Water probes located inside cooking chamber maintain water level during cooking, eliminating the need to manually maintain water level. Additional High Water Indicating Light and Buzzer included with this option.
- Extended Parts and Labor Warranty up to 5 years.

## ACCESSORIES (SOLD SEPERATELY)

- Single unit stand with standard adjustable bullet feet.
- Single unit stand with casters.
- Double unit stand with standard adjustable bullet feet.
- Double unit stand with casters
- 4" drain pan (standard 4" steam table pan).
- Fixed Drain Pan (allows for fixed drain installation). Pan slides onto drain pan rails and hooks onto drip edges already on steamer. Includes 3/4" MNPT drain fitting and a 3/4" FNPT to 3/4" MGH adapter.

## STERLING SP SERIES ELECTRIC

### 6-PAN HIGH EFFICIENCY BOILERLESS CONVECTION STEAMER



## SPECIFICATIONS

Single compartment connectionless steamer with capacity for 6 full size 2.5 inch or 4 full size 4 inch steam table pans. Requires no water or drain connection. Controls include adjustable hold thermostat with thermometer, 60 minute manual timer with settings for timed or continuous cook and a 2 position switch for batch or à la carte cooking. Dual steam impingement system for directing convection steam evenly over each pan from both sides. Mirror finish interior sides. Heavy duty 14 gauge cooking compartment and exterior door. Electric heating element mounted underneath chamber and not exposed to mineral or lime buildup. Four inch adjustable legs included. Power required, 208, 240, or \*480VAC 60Hz, 1 or 3\* phase. \*480V units are 3 phase only and are not UL Listed

### Exterior Dimensions:

23"w x 30"d x 30"h.

UL Listed, UL Classified to NSF/ANSI 4 and exceeds Energy Star® performance levels.



# STERLING SP SERIES ELECTRIC 6-PAN HIGH EFFICIENCY BOILERLESS CONVECTION STEAMER

## WATER SUPPLY

Feed water for reservoir: 10 - 60 PSI, 32 - 175 ° F, 3/4" MGHT,  
Use NSF approved hose.

## EQUIPMENT CLEARANCE

3" - Left, 3" - Right and 4" - Rear.

## CAPACITY

Compartment holds: six 12"x 20"x 2.5" or four 12"x 20"x 4"  
Steam Table Pans.

## NOTE:

- It is the responsibility of the owner and installer to comply with local codes for installation.
- This appliance is manufactured for commercial installation only and is not intended for household use.

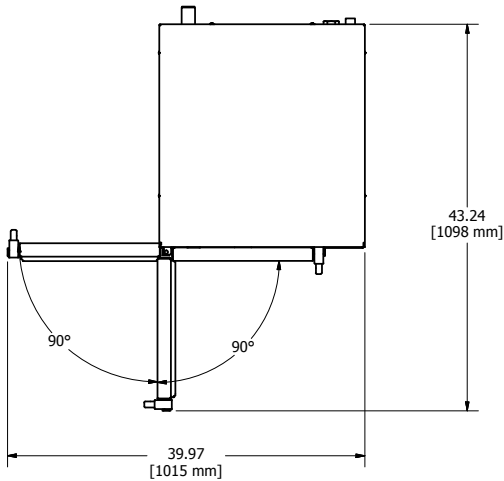

TOP VIEW

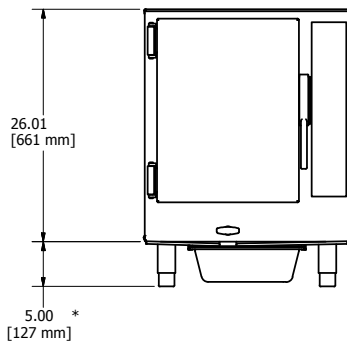

FRONT VIEW

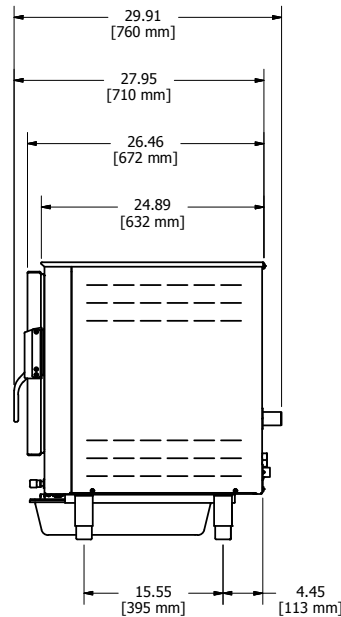

RIGHT SIDE VIEW

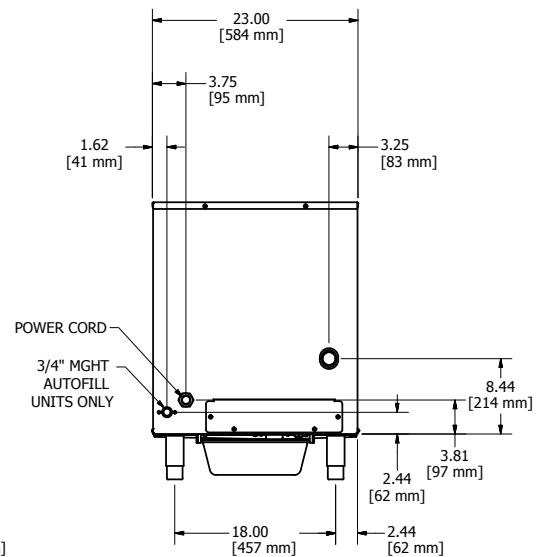

REAR VIEW

\* Legs adjust from 4" - 6" (102 - 152mm)

Model Number	Volt/Hz/Phase	kW	Amps	NEMA Plug
<b>STERLING SP SERIES ELECTRIC (Auto-Fill)</b>				
SP208-6-1-AF	208/60/1	6.23	29.95	L6-30P
SP208-10-1-AF	208/60/1	10.0	48.08	6-50P
SP208-10-3-AF	208/60/3	10.0	27.76	L15-30P
SP208-14-3-AF	208/60/3	14.4	39.97	15-50P
SP240-6-1-AF	240/60/1	6.23	25.96	L6-30P
SP240-10-1-AF	240/60/1	10.0	41.67	6-50P
SP240-10-3-AF	240/60/3	10.0	24.06	L15-30P
SP240-14-3-AF	240/60/3	14.4	34.64	15-50P
*SP480-12-3-AF	480/60/3	12.0	14.43	L16-20P

Model Number	Volt/Hz/Phase	kW	Amps	NEMA Plug
<b>STERLING SP SERIES ELECTRIC (Manual-Fill)</b>				
SP208-6-1-MF	208/60/1	6.23	29.95	L6-30P
SP208-10-1-MF	208/60/1	10.0	48.08	6-50P
SP208-10-3-MF	208/60/3	10.0	27.76	L15-30P
SP208-14-3-MF	208/60/3	14.4	39.97	15-50P
SP240-6-1-MF	240/60/1	6.23	25.96	L6-30P
SP240-10-1-MF	240/60/1	10.0	41.67	6-50P
SP240-10-3-MF	240/60/3	10.0	24.06	L15-30P
SP240-14-3-MF	240/60/3	14.4	34.64	15-50P
*SP480-12-3-MF	480/60/3	12.0	14.43	L16-20P

Note: \* 480V units are 3 phase only and are not UL Listed



SMSD - SS051226

Page 2 of 3

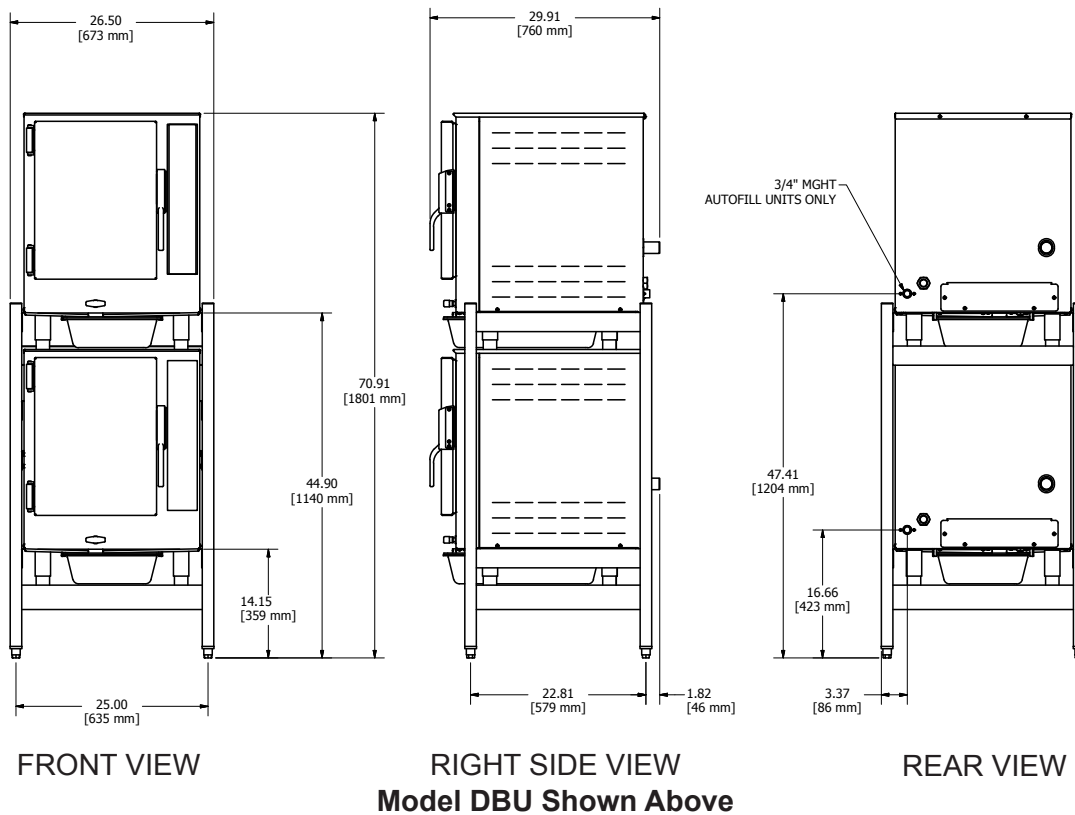
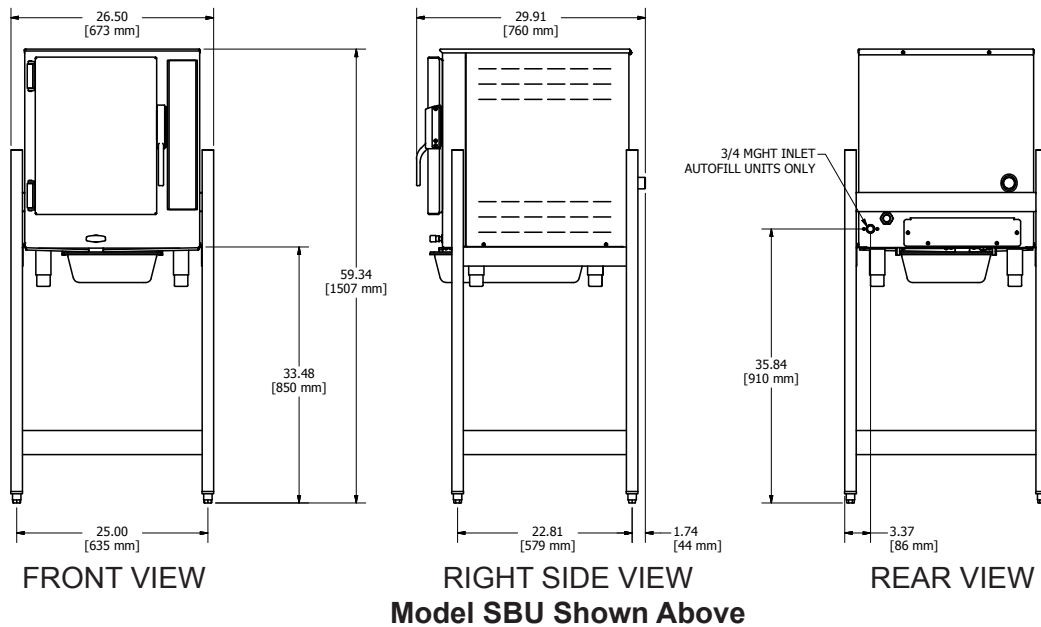

Note: Dimensions do not change for variations in Model Numbers. Bullet Feet and Flanged feet have a 1" adjustment.

Model Number	Steamer Capacity	Style
<i>Stand Selector</i>		
SCA	One	5" Caster
SBU	One	Adjustable Bullet Foot
SFL	One	Adjustable Flange Foot

Model Number	Steamer Capacity	Style
<i>Stand Selector</i>		
DCA	Two	5" Caster
DBU	Two	Adjustable Bullet Foot
DFL	Two	Adjustable Flange Foot

